

SIDE VIEW

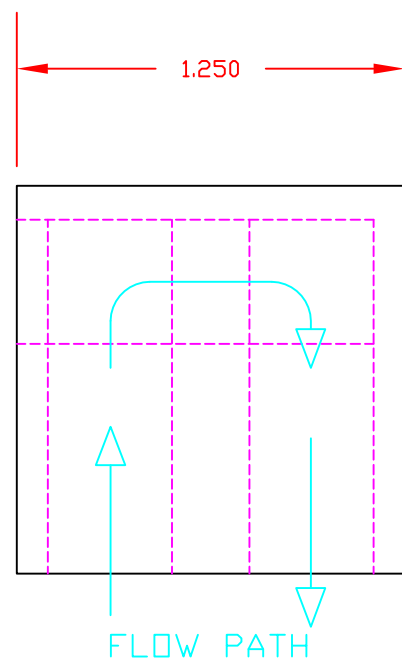

TOP VIEW

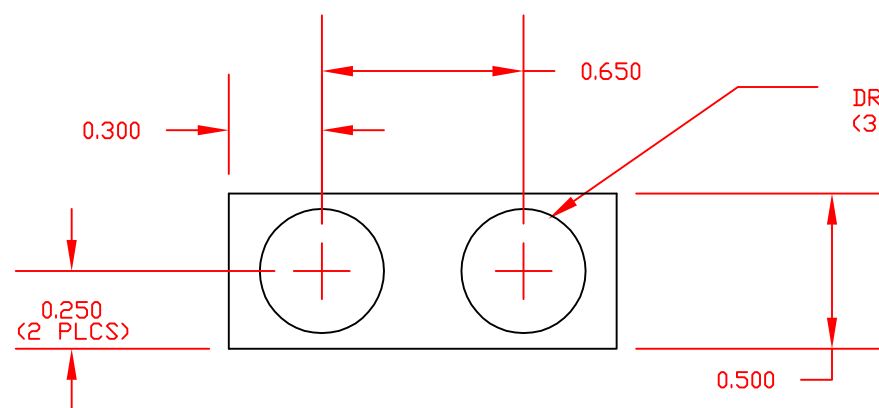



FRONT VIEW

DRILL 1.10-1.14" DEEP TAP 1/8" NPT 0.35" DEEP (3 PLCS)

NOTES:

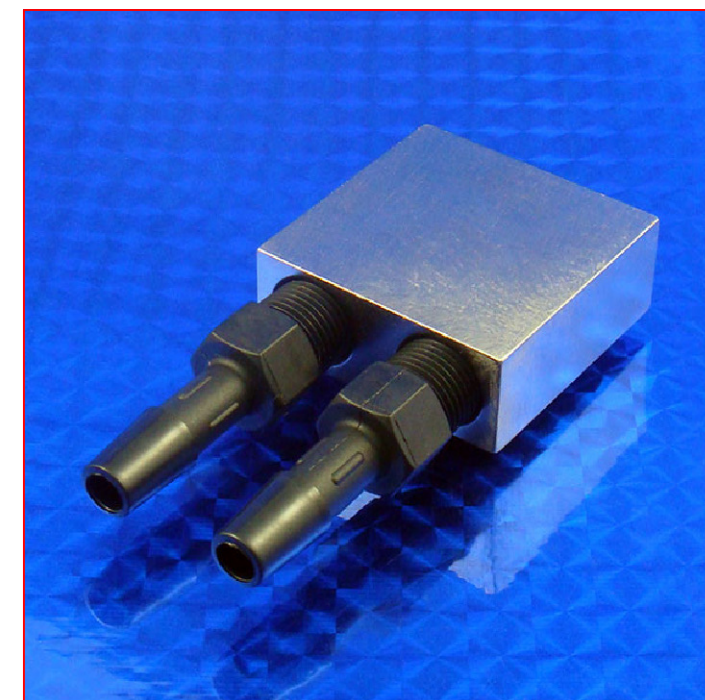
- 1) MATERIAL: COPPER (Alloy 110, 101 or 145)
- 1) FINISH: ELECTROLESS NICKEL PLATING



REV.	DATE	DESCRIPTION	REV.	DATE	DESCRIPTION	SCALE	 11941 Industrial Park Road, STE 5 Bishopville, Maryland 21813	THIS DOCUMENT IS THE EXCLUSIVE PROPERTY OF CUSTOM THERMOELECTRIC INC. AND THE INFORMATION CONTAINED THEREIN IS CONFIDENTIAL, PROPRIETARY INFORMATION OF CUSTOM THERMOELECTRIC. NEITHER THE DOCUMENT NOR ITS INFORMATION MAY BE DISCLOSED, COPIED, OR USED IN WHOLE OR IN PART WITHOUT THE PRIOR WRITTEN CONSENT OF CUSTOM THERMOELECTRIC INC.			
A	2/2/2011	Initial release				NOT TO SCALE			DRAWN BY	DATE	CHECKED
						MATERIAL	UNLESS OTHERWISE SPECIFIED ALL DIMENSIONS ARE IN INCHES & PER ANSI Y14.5 FRACTIONAL: ± .03 DECIMAL: ± .XX .01 , ± XXX .005 FILLET RADIUS: .010 MAXIMUM THREADS: CLASS 2 ALL DIAMETERS CONC. WITHIN .005 T. I. R. SURFACES TO BE PERPENDICULAR WITHIN .005 T. I. R. SURFACES TO BE PARALLEL WITHIN .005 T. I. R. HOLE ANGULAR TOLERANCE ± 0° 5' ALL OTHER ANGULAR TOLERANCES TO BE ± 0° 30' REMOVE ALL BURRS AND EDGES	-	2-02-11	-	
						FINISH		TITLE WATER BLOCK 1.25" x 1.25" x 0.50" R1 (IN/OUTLET ON SAME SIDES)			
						NO. REQUIRED		SIZE	DRAWING NUMBER	SHEET	REV.
						1		B	WBA-1.25-0.5-CU-NP	1 OF 1	A
						NEXT ASSEMBLY					
						-					
						CAD#					
						-					
						SIMILAR TO:					
						-					